

Product description VOSS quick connect system 246 AX

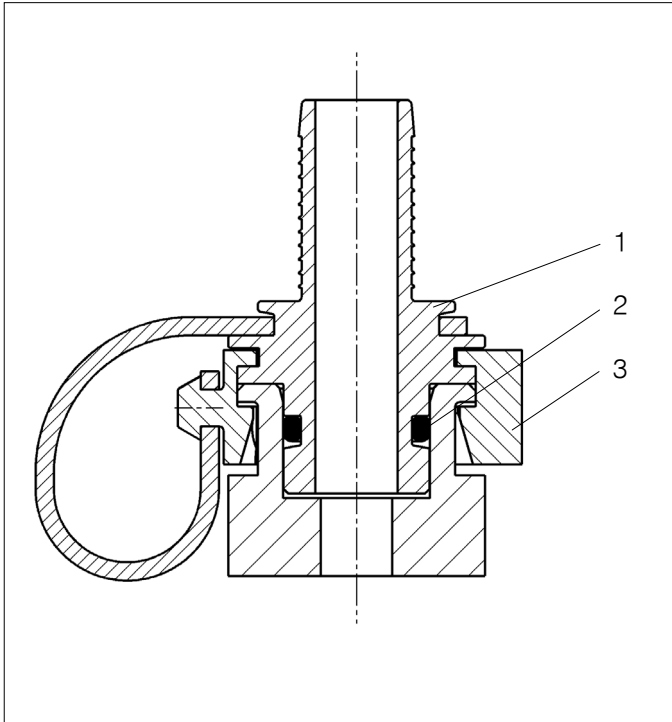

Fig. 1: Functional drawing

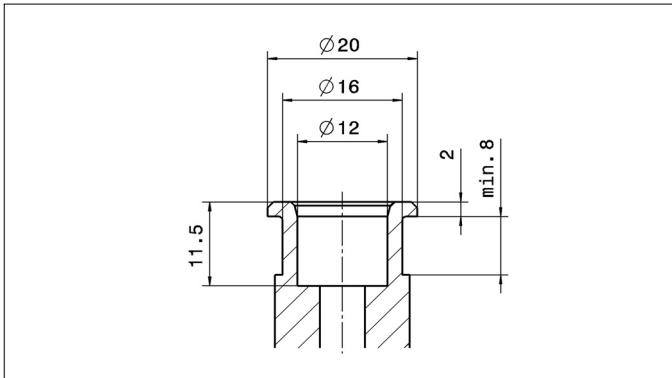

Fig. 2: Connecting port nominal size 8

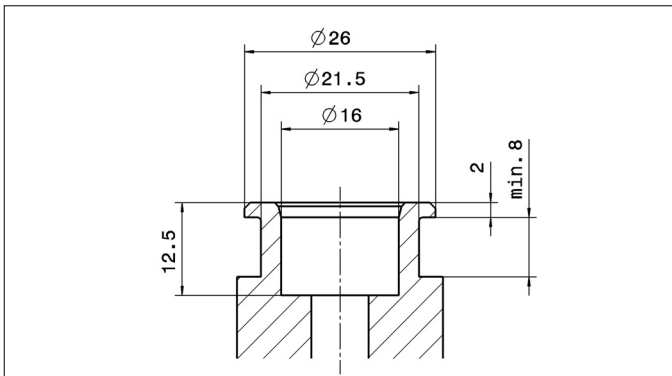

Fig. 3: Connecting port nominal size 12

1. Purpose of use

The VOSS quick connect system 246 is used primarily as connecting element between fuel line and fuel component as well as inline connector. It permits safe and rapid assembly.

2. Range of application

The VOSS quick connect system 246 is designed for a temperature range between -40°C and $+100^{\circ}\text{C}$. For special applications we offer solutions up to $+140^{\circ}\text{C}$ permanent load.

Depending on operating conditions, the system is applicable at an operating pressure up to 20 bar for nominal size 8 and 12 bar for nominal size 12.

The system is available with the following sealing materials depending on the medium used:

- NBR for diesel fuel acc. to DIN EN 590
- FPM for diesel fuel acc. to DIN EN 590 and for diesel fuel made from vegetable oil methyl ester acc. to DIN 51 606 - PME (RME)

Applications with other media, temperatures and pressures on request.

The VOSS assembly instructions have to be observed.

3. Single components

The VOSS quick connect system 246 AX (see fig. 1) is composed of:

1 Plug

For straight plugs see figs. 4 and 5

For elbow plugs see figs. 6 and 7

2 O-Ring

3 Retaining clip with rubber strap

The plug is suitable for connecting nylon tubes or hoses.

Quick connect system 246 AX requires a connecting port at the component according to figs. 2 or 3 or an adequate adapter.

A technical data sheet of the connecting port can be provided if required.

Connecting ports and adapters should preferably be made of brass or steel. Depending on operating conditions, ports and adapters made of aluminum or nylon are possible.

If required, poka yoke solutions can be supplied, e. g. for feed and return lines (nominal sizes 8 and 12).

4. Functional description

The connection of VOSS quick connect system 246 AX is made by inserting the plug into the connecting port or the adapter, while paying attention to the assembly instructions. The retaining clip locks behind the flange of the connecting port or the

5. Other

adapter. Then the connection is completely assembled and tight.

Variants, other sizes and line assemblies are available on request.

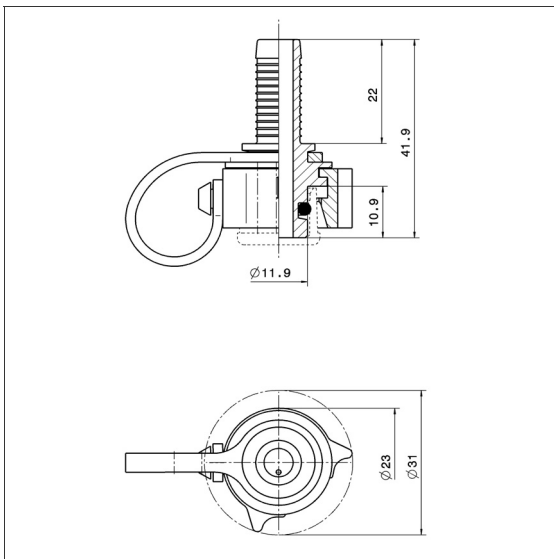

Fig. 4: Straight plug nominal size 8

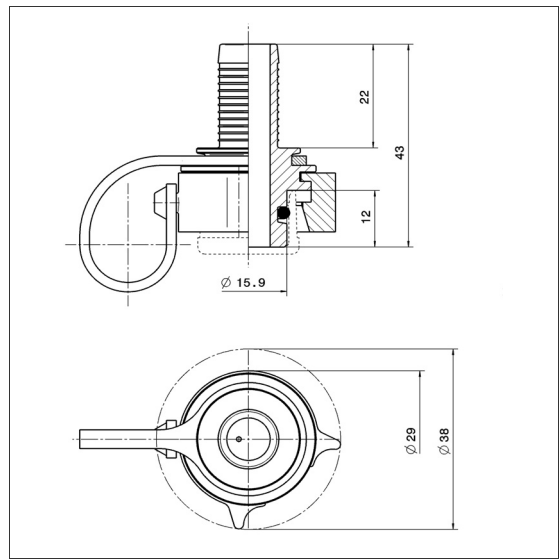

Fig. 5: Straight plug nominal size 12

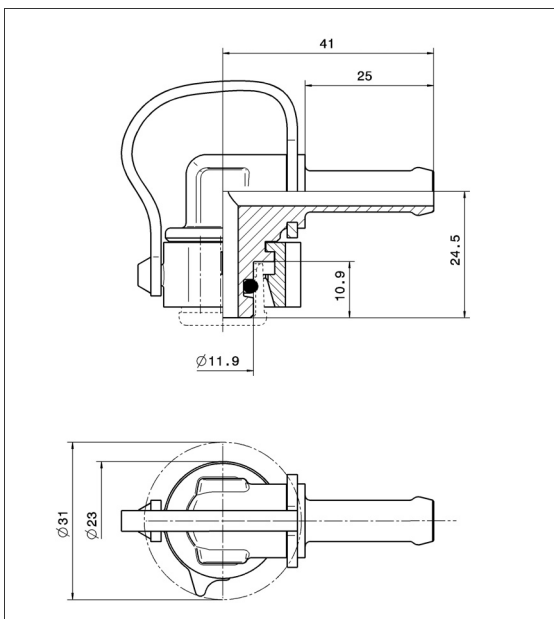

Fig. 6: Elbow plug nominal size 8

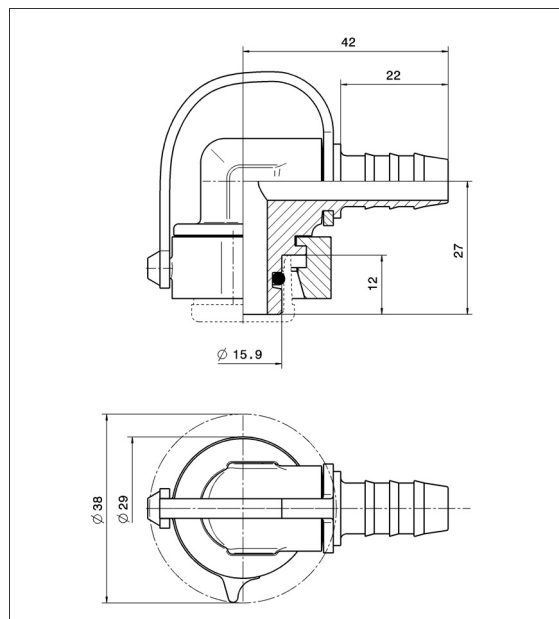

Fig. 7: Elbow plug nominal size 12