

Product information pressure sensor

Pressure sensor for pneumatic systems



- Only one connection point (e.g. at the air-suspension-bellow) required for compressed air and sensor connection
- For different applications e.g. auxiliary circuits or air suspension
- Rotatable sensor
- Small installation space
- Easy integration of pressure sensors into the system
- Flexible handling even after assembly
- Fewer components and less weight
- Easy assembly with VOSS manual assembly tool or similar tool for electrical components
- Available with different VOSS quick connect systems and various shapes, based on customer requests

For easy integration and different applications in compressed air systems

System 232 pressure sensor design

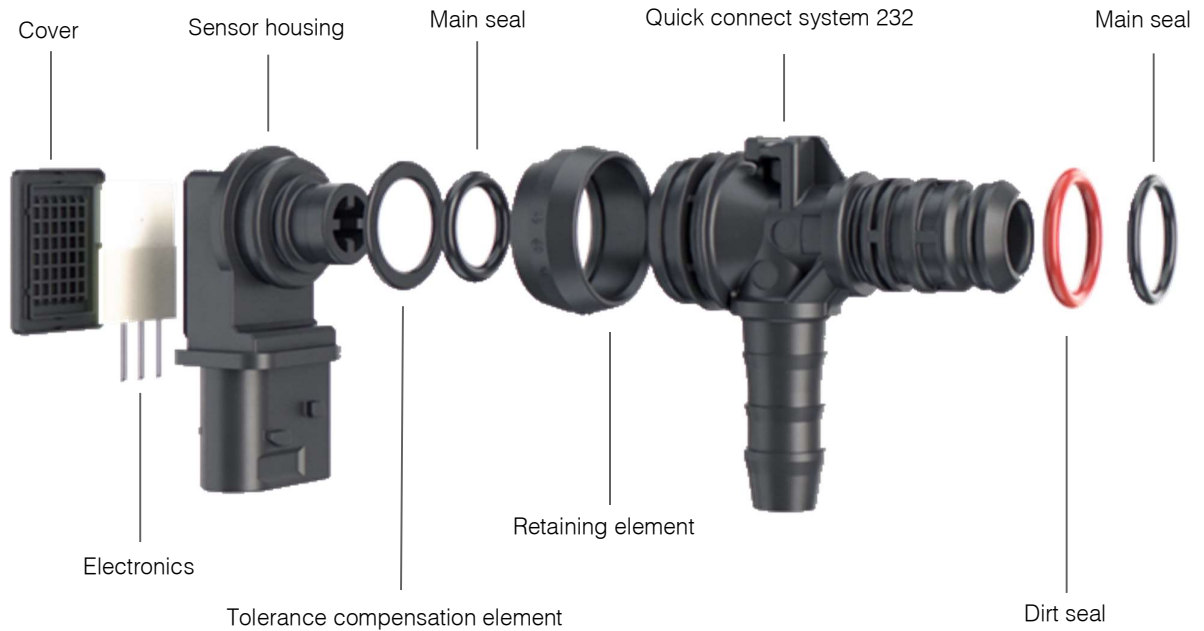

- E-Connector: Tyco HDSCS 3-pin code "B"
- Contact coating: Tin-plated
- Pressure range: 0.85 bar – 16.85 bar (absolute)
- Overpressure: 23 bar ($t \leq 1$ minute)
- Supply voltage: 8V – 32V
- Overvoltage: 35V
- Output signal: 0,5V – 4,5V
- Current consumption: ≤ 15 mA
- Temperature range: -40°C to +100°C (high temperature on request)
- Total error: $\leq \pm 1,5\%$ (-20°C to +80°C)
 $\leq \pm 2,5\%$ (remaining temperature range)
- Validation: based on ISO 16750

